

# 社会実装② AIによる伝熱性能予測

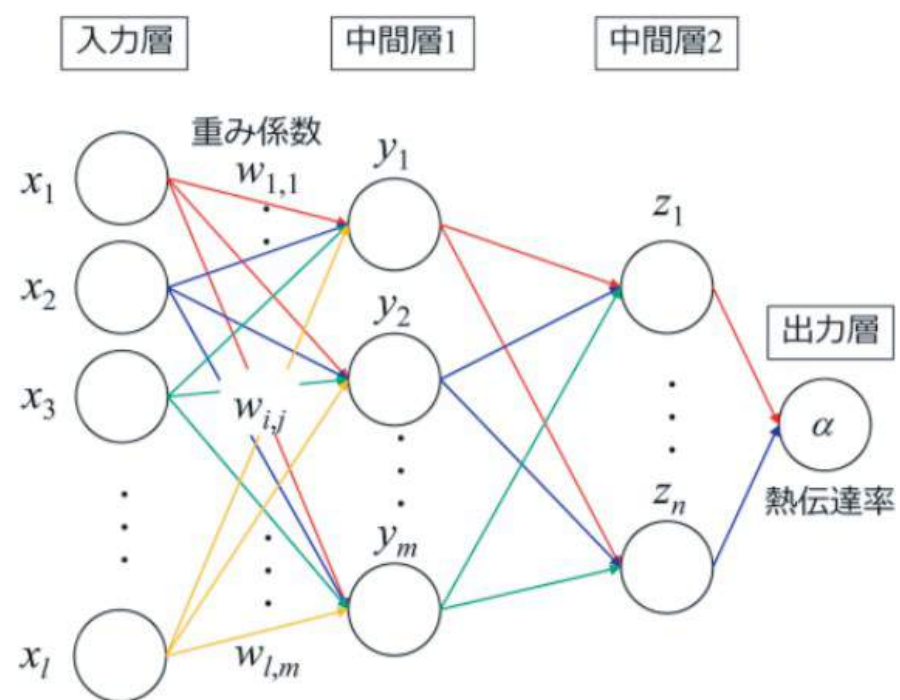

Fig.2 Conceptual diagram of ANN

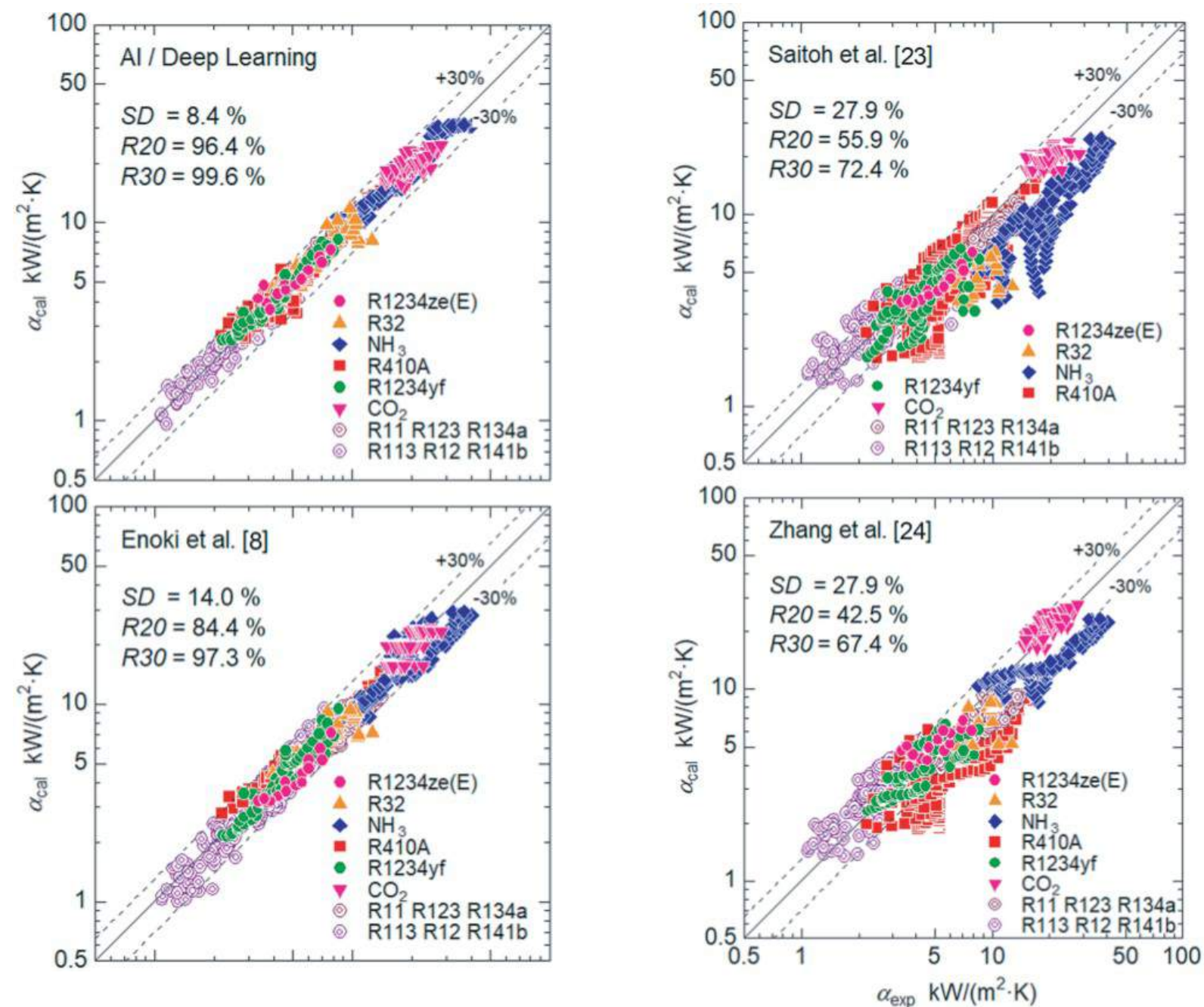
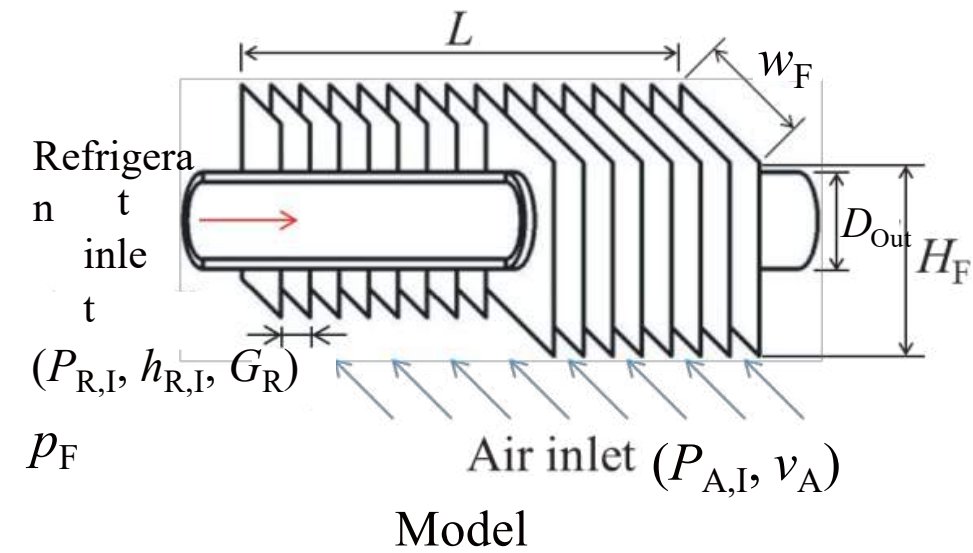

Fig.4 Comparison of the predictions and the experimental data [4, 9-19]

# 社会実装③ AIによるデバイスの最適化



Fin&Tube heat exchanger



We use genetic algorithm to optimize heat exchanger

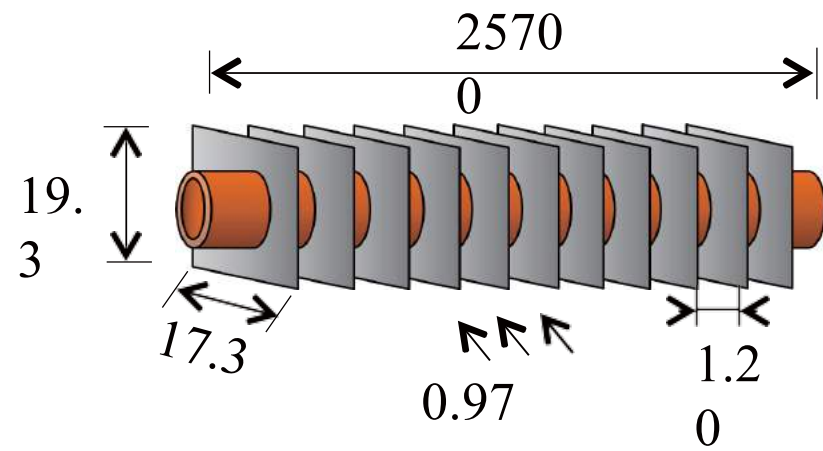

Conventional

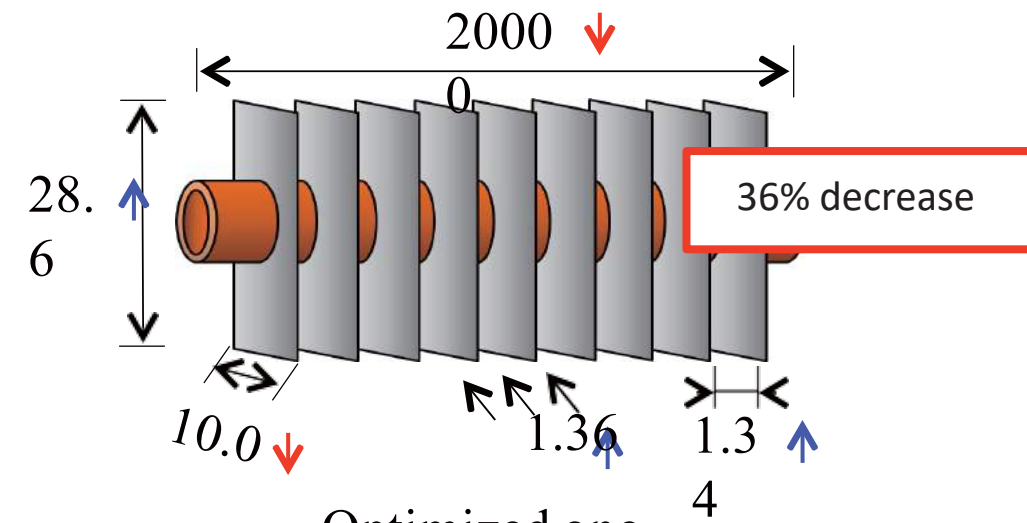

Optimized one

國田ほか5名, 遺傳的アルゴリズムによる空気調和機用フィンチューブ熱交換器の最適化, 2015年度 日本冷凍空調学会年次大会